

A Logística na BOSCH Car Multimedia Portugal, Lda.

Caso prático de aplicação do Value Stream Mapping

Carmen Belo
19.Novembro.2009

Agenda

- Apresentação do Grupo BOSCH
- Apresentação da empresa
- Princípios BPS
- Aplicação prática do VSM
- Desafios

- Mais de 100 anos de história
- Mais de 280 mil colaboradores
- Presença em mais de 50 países por todo o mundo
- Mais de 270 subsidiárias

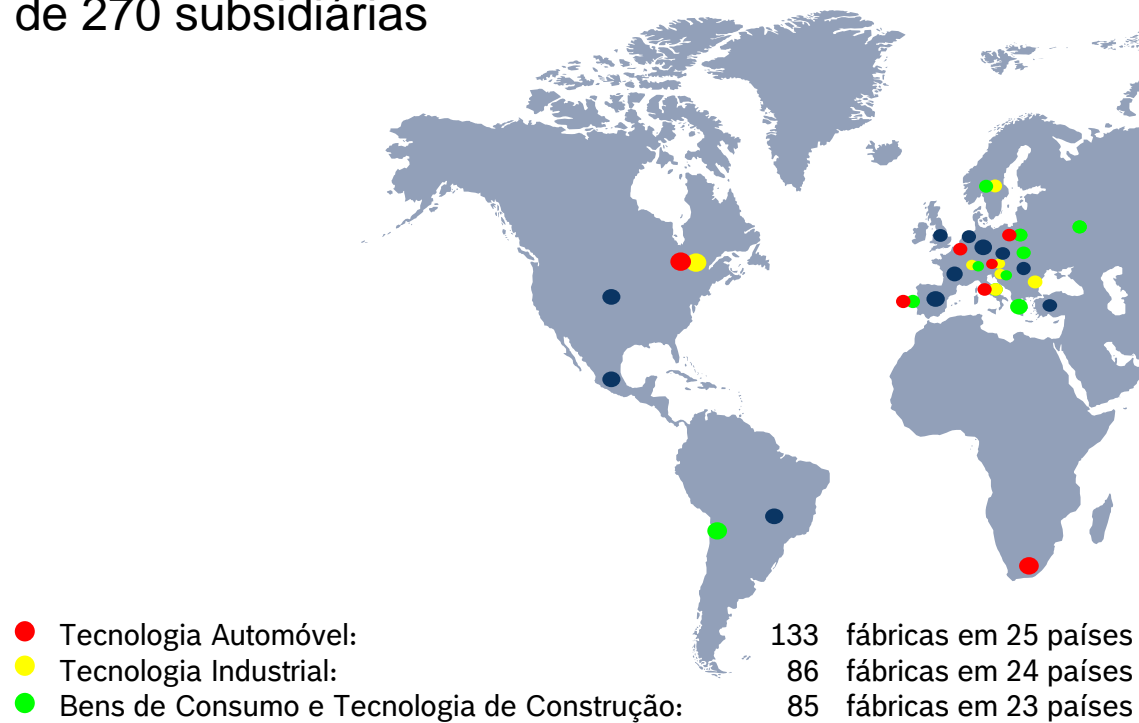

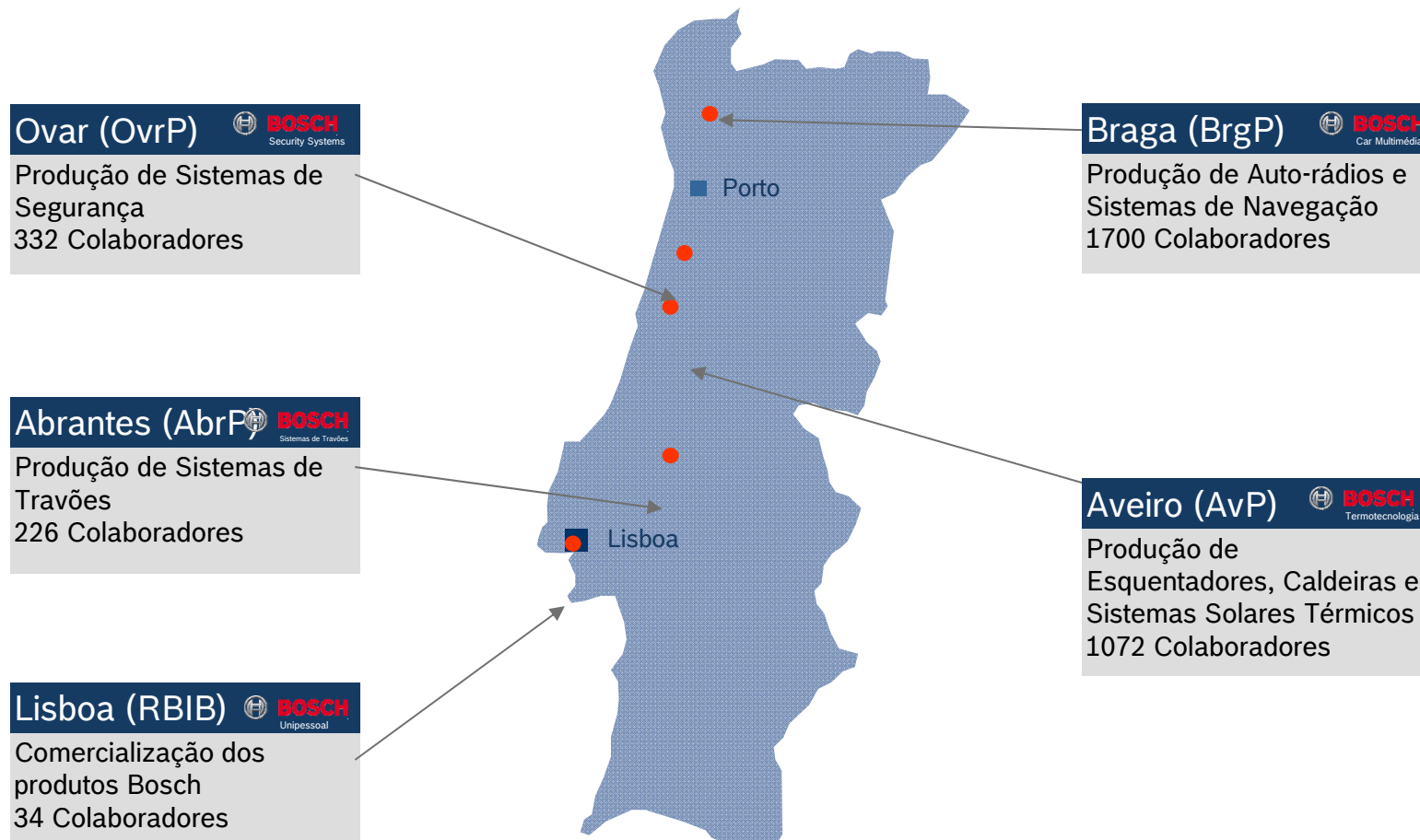

BOSCH Car Multimedia Portugal Lda.



Auto-rádio
FIAT



Auto-rádio com
"touch screen"
VW MID



Sistema de
Navegação
VW/SEAT/SKODA



Controladores para
Caldeiras
Bosch -TT



BOSCH Car Multimedia Portugal Lda.

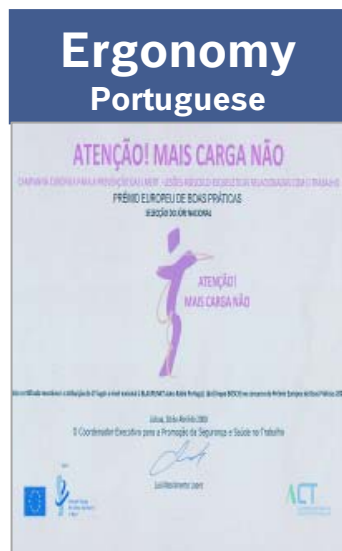

2008

Volume de negócios	347 Mio €
Produção	3.982.000 un
Volume de formação	90 081 h
Área total	66.692 m2
Colaboradores	1.700

Bosch Braga 2008



**Rodoviário: > 1275 camiões completos
(inbound e outbound)**



Aéreo: > 1280 envios



Marítimo: > 195 contentores

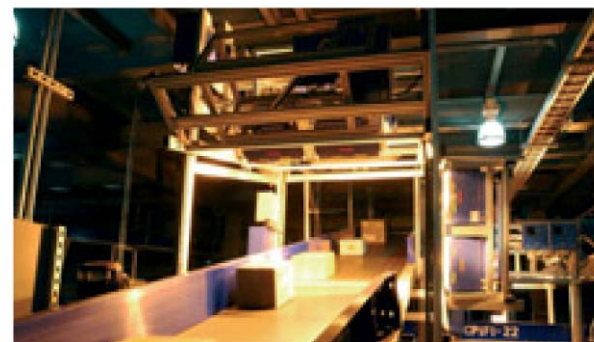

Expressos : > 3248 envios

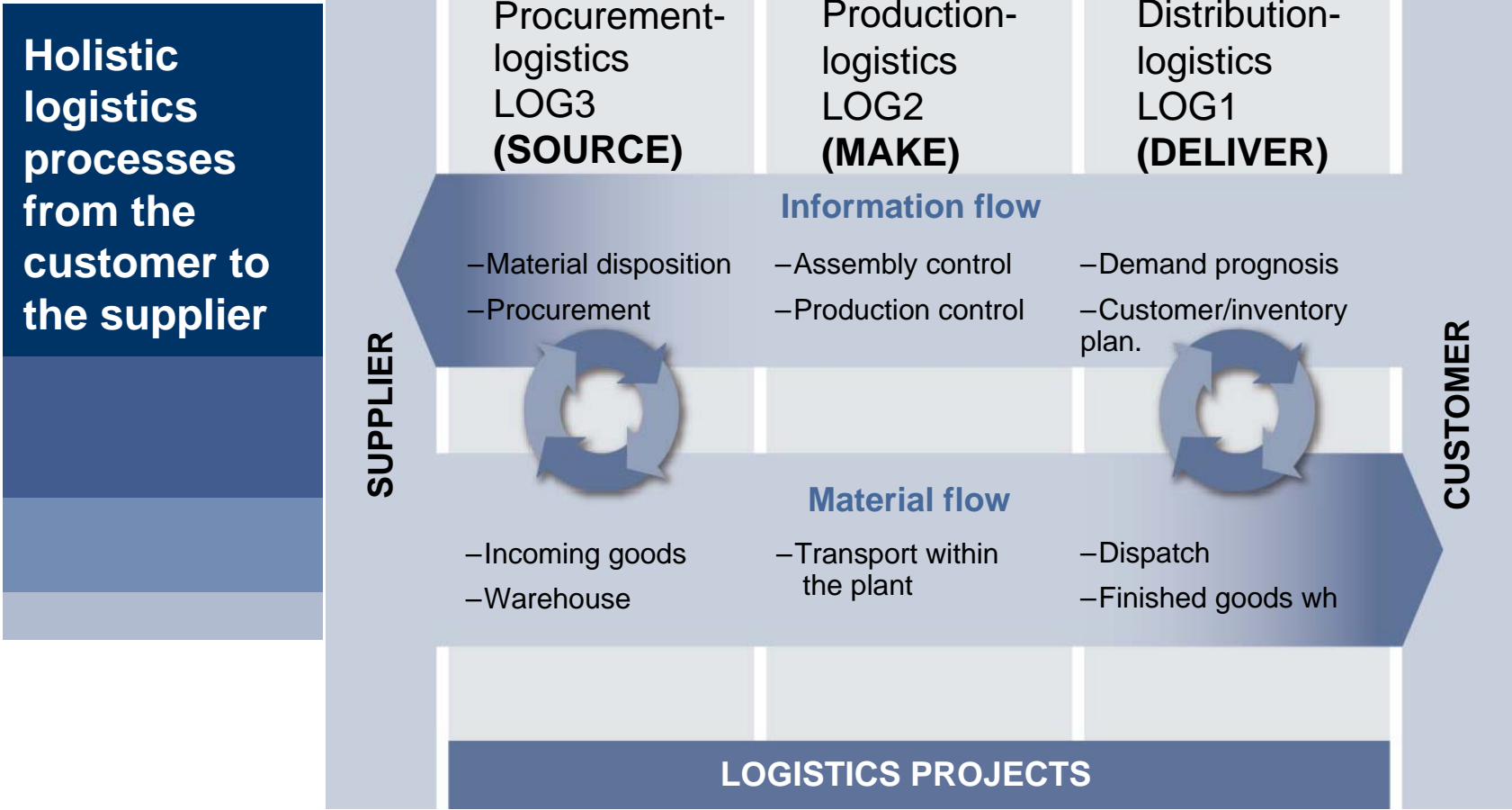

Bosch Production System

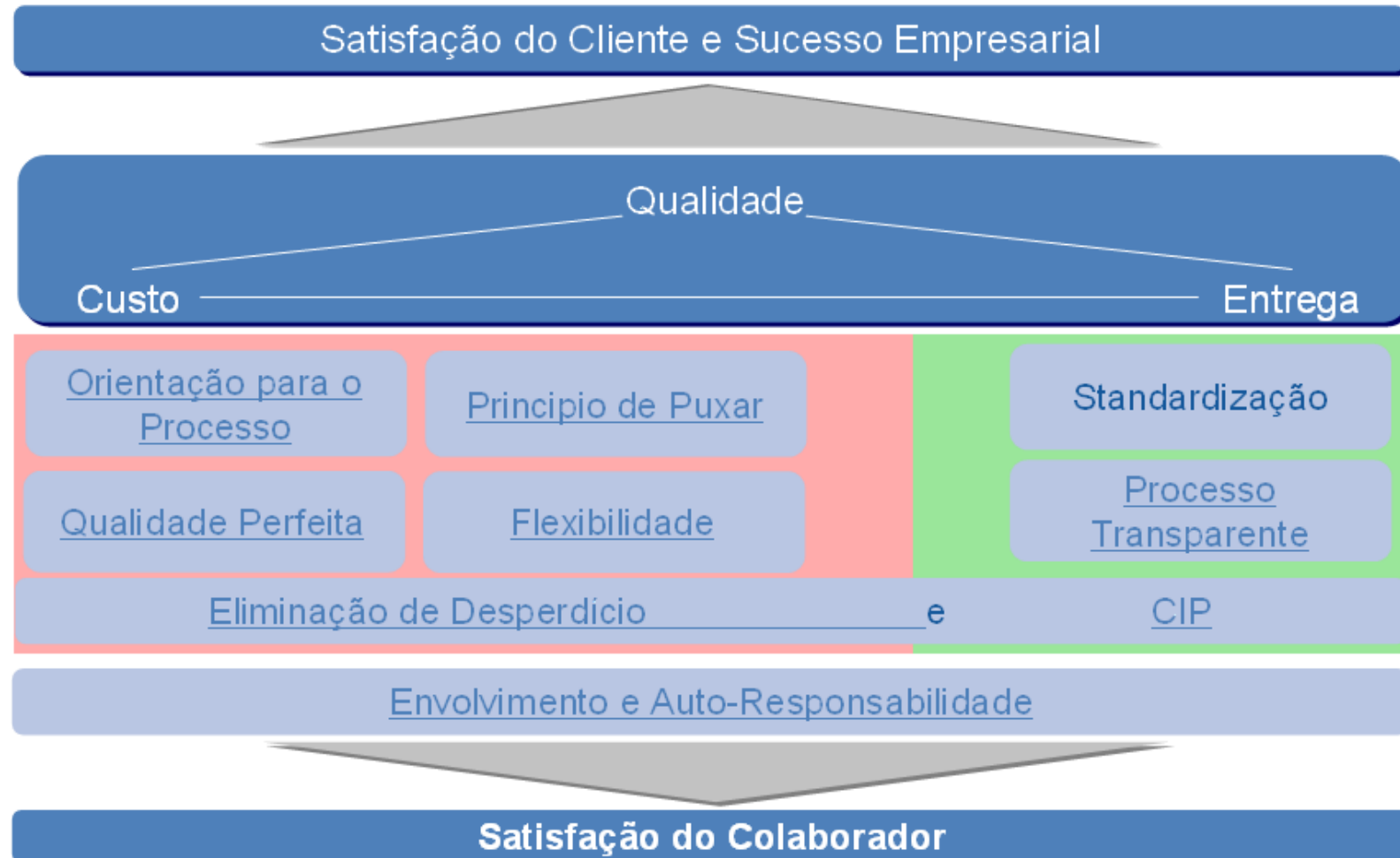

Value Stream Mapping (VSM)

Função: O VSM estrutura as actividades e projectos ao longo da cadeia de valor para atingir melhorias efectivas globais e sustentadas em qualidade, custo e nos prazos de entrega.

Vantagens:

- Identifica em toda a cadeia de valor (Fornecedor/ Cliente) o fluxo de material e informação com linguagem standard
- Permite identificar com facilidade o desperdício e criar um plano de acções com o objectivo de elaborar o VSD.

Estrutura:

- VSM: o estado actual da cadeia de valor (Fluxo de informação e material)
- VSD: estado futuro
- Métricas e plano de acções
- Layout com fluxo de materiais

Value Stream Mapping (VSM)

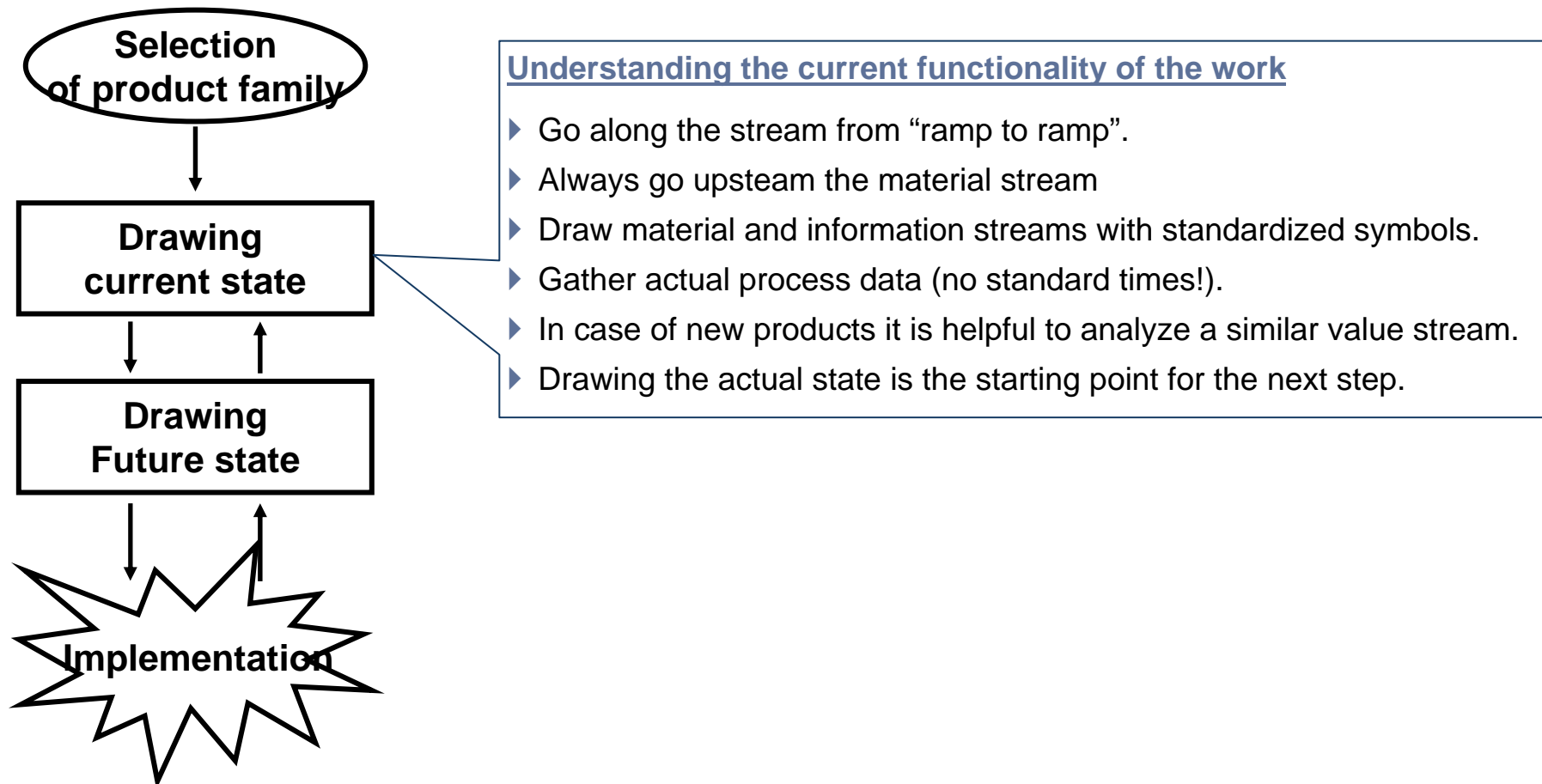

Value Stream Mapping (VSM)

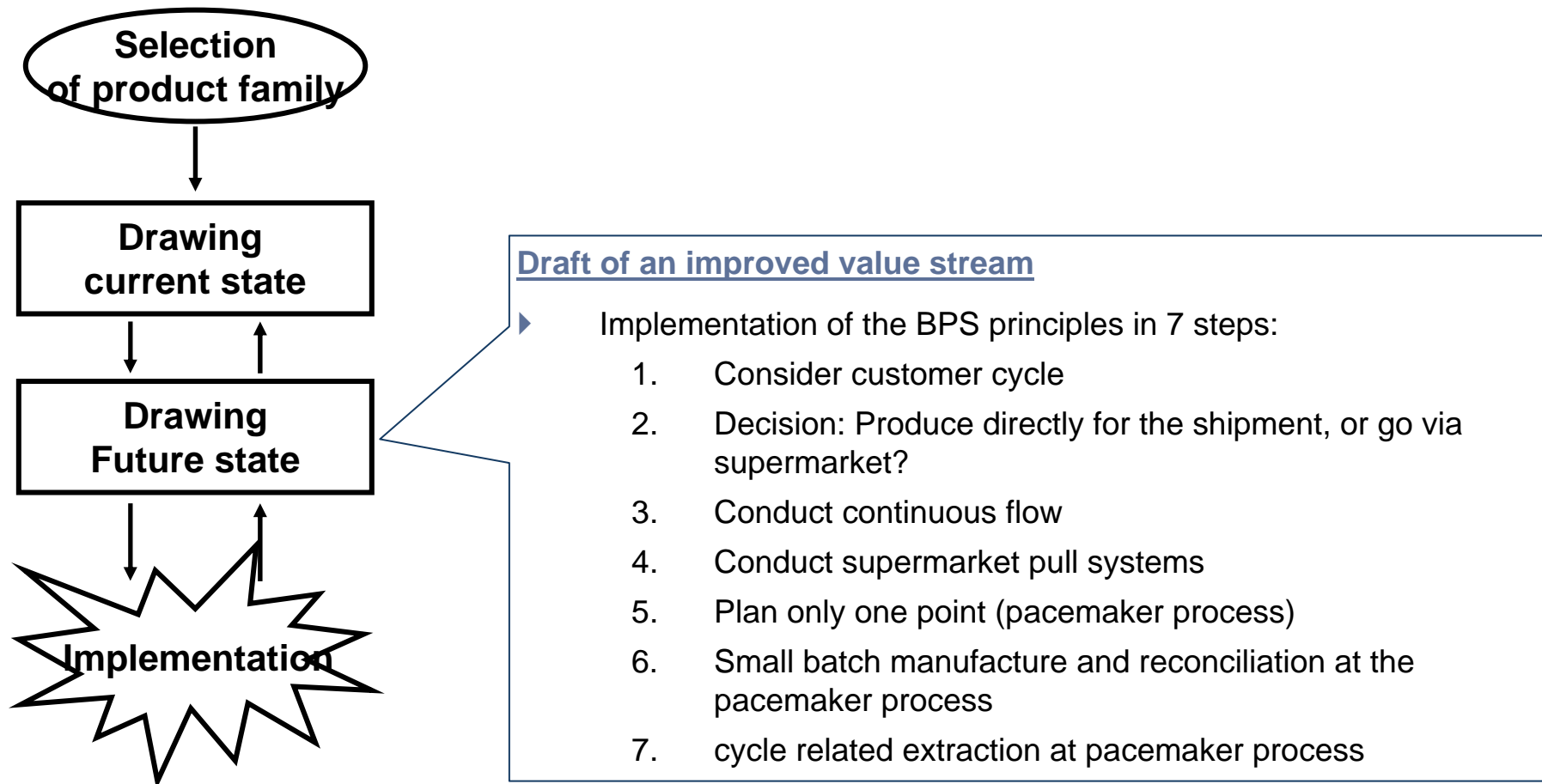

Caso prático

VSM 2009

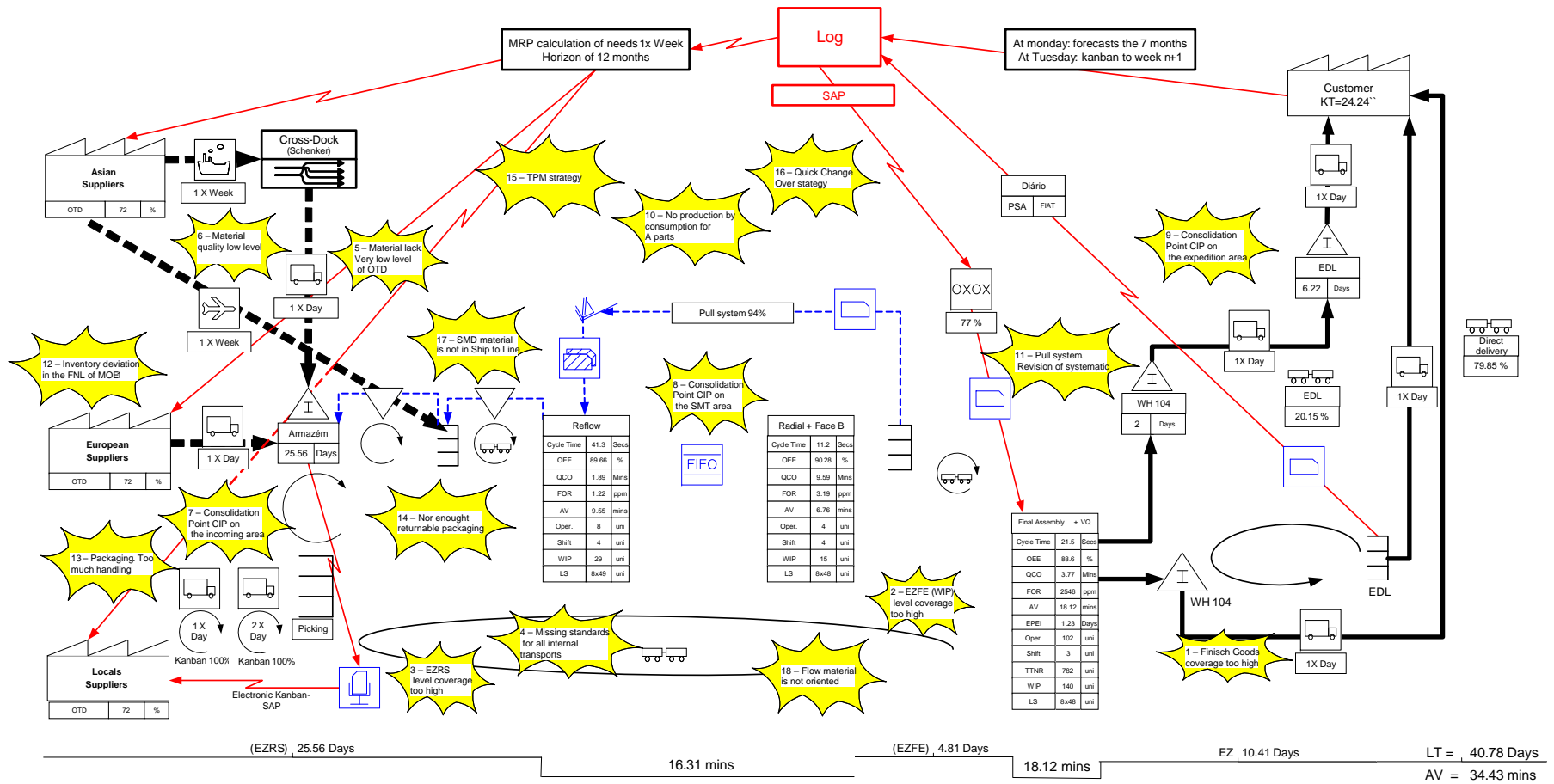

Desafios

- Mudança de paradigma
- Perspectiva global versus departamental
- Exposição de desperdícios
- Estabelecimento de compromissos

Obrigada,
Carmen Belo

carmen.belo@pt.bosch.com

